

Date:

November 2018

Description:

Old Man Emu BP-51 High Performance Bypass Shock Absorbers

Application:

Land Rover Defender 110 / 130 Long Travel

Part No. & Barcode:

Refer to table on page 3

Product Group:

Refer to table on page 3

Availability Date:

January 2019



Product Specification

BP-51 LONG TRAVEL NOW RELEASED FOR LAND ROVER DEFENDER 110/130:

Old Man Emu is pleased to release the latest application of BP-51 High Performance Bypass Shock Absorbers engineered specifically for the OME Defender Long Travel Application. This package consists of two front dampers, two rear dampers and two fit kits. The fit kits include all the required spacers and brackets to allow the fitment of a longer travel, larger diameter BP-51 damper with remote reservoir. Fit kits include a front shock turret (tower) replacement, front and rear bump stop spacers, sway bar spacer, rear upper shock mount and all necessary hardware for correct fitment of the BP-51 remote reservoir.

The dampers for the Defender Long Travel have been tuned specifically and designed for the OME's current range of Long Travel coil designs. Particular attention needs to be made to coil selection to ensure coil entrapment due to the longer travel design.

Recommended compression and rebound settings can be found in the supplied fitting instructions for loading scenarios that utilise the various spring options available from the OME current Defender Long Travel Application. The fitting instructions include detailed information for correct installation of the shock absorber and reservoir placement.

FRONT BP-51 SELECTION:

Along with two specifically tuned front BP-51 shock absorbers, the front fit kit includes replacement front shock turrets, front sway bar spacers, front bump stop spacers and reservoir mount assembly.

It is important to note the a front driveshaft **MUST** be replaced/modified with Double Cardan Joints and checked for uni bind with the OME longer shocks installed at full droop.

SPRINGS: Front spring selection must be from the current OME Defender Long Travel application. Long travel application guide attached separately.

Front Shock Turret (Tower):

With the hose for the reservoir mounting to the top of the BP-51 damper, which is where the shock mounts, the OME engineers have designed and developed a new shock turret. The new turret allows to run the BP-51 remote reservoir hose through it. A new bracket to mount the remote reservoir was also developed.



Bump Stop Spacer:

A fabricated bump stop 30mm spacer was designed and utilises the factory bump stop and is an easy bolt on solution. The front bump stop spacer is supplied with the front fit kit.



Sway Bar Spacer:

With the increase down travel the driveshaft will come in contact with the sway bar, to overcome this OME engineers have designed a sway bar spacer fit kit and utilises existing mounts, again an easy bolt on solution. Front sway bar spacers are included in the front fit kit.

Caster correction is addressed by our existing replacement caster bush, and trim packers are available if required for ride height tuning.



REAR BP-51 SELECTION:

Along with two specifically tuned rear BP-51 shock absorbers, the rear fit kit includes a replacement rear upper shock mount, rear sway spacers, rear bump stop spacers and reservoir mount assembly.

SPRINGS: Rear spring selection must be from the current OME Defender Long Travel application. Long travel application guide attached separately.

Rear Upper Shock Mount:

A rear upper shock mount bracket was developed and changes the top mount type from an eye to a pin shock mount. This was developed to improve the articulation of the mount and reduce load on the mount components.



Bump Stop Spacer:

A fabricated bump stop 30mm spacer was designed and utilises the factory bump stop and is an easy bolt on solution. The rear bump stop spacer is included with the rear fit kit.

Sway Bar Spacer:

With the longer travel in the rear suspension, the OME engineers discovered that the droop was limited now by the rear sway bar. The introduction of a fabricated sway bar spacer for the rear enables full benefit of the longer travel shock. Rear sway bar spacers are included in the rear fit kit.

Part Number	Description	Qty Req.	Prod. Group	Barcode
BP5160035	SHOCK: DEFENDER FRONT	2	287	9332018056122
BP5160036	SHOCK: DEFENDER REAR	2	287	9332018056139
VM80010036	KIT: DEFENDER 110 130 FRONT	1	321	9332018056146
VM80010037	KIT: DEFENDER 110 130 REAR	1	321	9332018056153

Vehicle Specific Applications:

- No fitting modifications are needed
- Fit kits developed specifically for the Defender
- All reservoir brackets have been integrated into the geometry of the Defender 110/130
- Included in the front fit kit is a replacement front shock turret, front sway spacers, front bump stop spacers and reservoir mount assembly.
- Included in the rear fit kit is a replacement rear upper shock mount, rear sway spacers, rear bump stop spacers and reservoir mount assembly.

Damper Specifications:

BP5160035

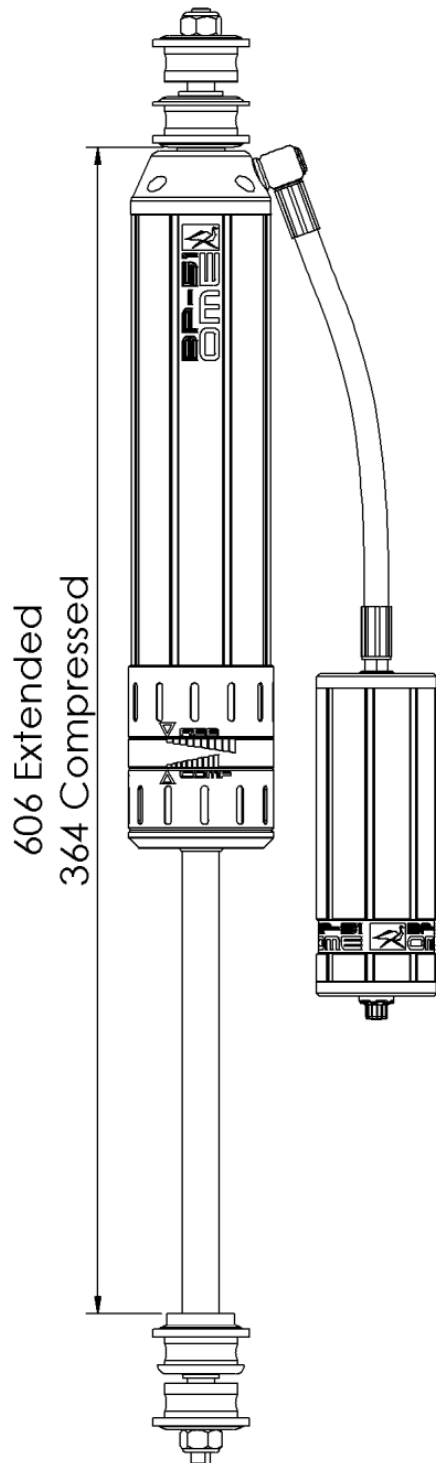

BP5160036

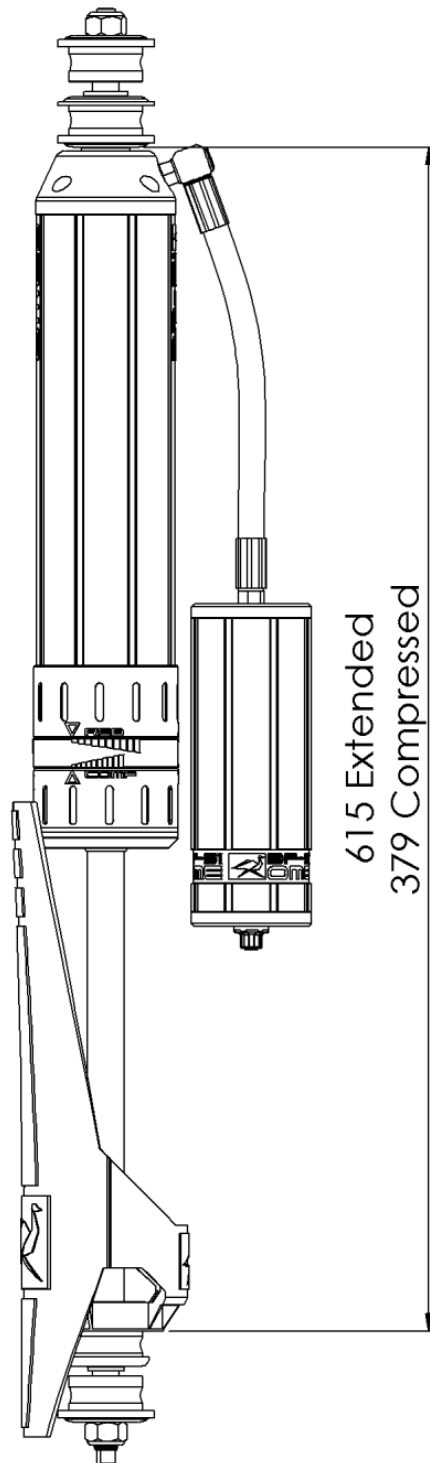

BP-51 Key Features and Benefits:

- Internal bypass, shim controlled, position sensitive damping
 - Provides comfort at ride height
 - Damping increases as you get closer to the end zone
 - Increased control at end zones
- Kidney bypass ports/51mm bore diameter
 - Maximum bore size and bypass diameter
 - Greater oil volume
 - More tuneable, ability to generate force
- Vehicle specific applications
 - No fitting modifications required
 - Fit kits developed specifically for the Defender
- External compression and rebound adjustment
 - On car adjustable
 - Independent adjustment of compression and rebound
 - Ultra wide range to suit varying loads and ride preferences
- Body/Reservoir/Components 6061 T6 aluminium construction
 - Heat dissipation
 - Corrosion resistance
- Type 3 40 micron hard anodised finish
 - Corrosion resistance
 - Abrasion resistance to stone damage
- DASH 6 high temperature teflon hose with high flow fittings
 - No restriction of oil flow
- High pressure nitrogen reservoir with aluminium, anodised floating piston
 - Increased oil volume
 - Maximise travel
- Adjustable spring preload/ride height
 - Cater for varying loads
 - Coil over applications only
- Impact resistant, replaceable shaft guard
 - Protects against stone damage
- Quality oversized rubber bushings
 - Durability
- Large teflon lined spherical bearings
 - Durability
 - Coil over applications only
- 3 year / 60000 km warranty